



Version	4
Total pages	21
Date	2006.6.8

Product Specification

6.5" color TFT-LCD module

MODEL NAME: C065GW01_V0

- (◆) Preliminary Specification
- (.....) Final Specification

Note: The content of this specification is subject to change.

© 2005 AU Optronics
All Rights Reserved,
Do Not Copy.



Contents:

A. Physical specification..... P3

B. Electrical specifications..... P4

1. Pin assignment..... P4

 a. TFT-LCD panel driving section..... P4

 b. Backlight driving section..... P5

2. Absolute maximum ratings..... P5

3. Environment conditions..... P6

4. Electrical characteristics..... P6

 a. Typical operating conditions..... P6

 b. Current consumption..... P6

 c. Backlight driving conditions..... P7

5. AC Timing..... P8

 a. Timing conditions..... P8

 b. Timing diagram..... P8

6. Power sequence..... P9

C. Optical specifications..... P10

D. Reliability test items..... P12

E. Packing form..... P13

Appendix:

Fig.1 Outline dimension of TFT-LCD module. **P14**
Fig.2 Sampling clock timing. **P15**
Fig.3 Horizontal display timing range. **P16**
Fig.4-(a) Horizontal timing. **P17**
Fig.4-(b) Detail horizontal timing. **P18**
Fig.5 Vertical shift clock timing. **P19**
Fig.6-(a) Vertical timing (From up to down)... **P20**
Fig.6-(b) Vertical timing (From down to up) **P21**

A. Physical specifications

NO.	Item	Specification	Remark
1	Display resolution (dot)	400RGB(W)×234(H)	
2	Active area (mm)	143.4(W)×79.326(H)	
3	Screen size (inch)	6.5(Diagonal)	
4	Dot pitch (mm)	0.1195(W)×0.339 (H)	
5	Color configuration	R. G. B. stripe	
6	Overall dimension (mm)	157.2(W)×89.8(H)×7.7(D)	Note 1
7	Weight (g)	155±5%	
8	Surface treatment	AG(25%) & with WV film	
9	Backlight unit	L type lamp	

Note 1: Refer to Fig. 1

B. Electrical specifications

1. Pin assignment

a. TFT-LCD panel driving section

Pin no	Symbol	I/O	Description	Remark
1	V _{GH}	I	Positive power for scan driver	
2	NC	-		
3	V _{CC}	I	Supply voltage of logic control circuit for scan driver	Note 4
4	GND	-	Ground for logic circuit	
5	V _{GL}	I	Negative power for scan driver	
6	NC	-		
7	STVD	I/O	Vertical start pulse	Note 1
8	UDC	I	UP/DOWN scan control input	Note 1,2
9	CKV	I	Shift clock input for scan driver	
10	OEV	I	Output enable input for scan driver	
11	NC	-		
12	NC	-		
13	STVU	I/O	Vertical start pulse	Note 1
14	VCOM	I	Common electrode driving signal	
15	AGND	-	Ground for analog circuit	
16	AV _{DD}	I	Supply voltage for analog circuit	
17	STHR	I/O	Start pulse for horizontal scan line	Note 1
18	LRC	I	LEFT/RIGHT scan control input	Note 1,2
19	CPH3	I	Sampling and shifting clock pulse for data driver	
20	CPH2	I	Sampling and shifting clock pulse for data driver	
21	CPH1	I	Sampling and shifting clock pulse for data driver	
22	MOD	I	Sequential sampling and simultaneous sampling setting	Note 3
23	DV _{DD}	I	Supply voltage of logic control circuit for data driver	Note 4
24	OEH	I	Output enable input for data driver	
25	VB	I	Alternated video signal input(Blue)	
26	VG	I	Alternated video signal input(Green)	
27	VR	I	Alternated video signal input(Red)	
28	NC	-		
29	STHL	I/O	Start pulse for horizontal scan line	Note 1
30	VCOM	I	Common electrode driving signal	

Note 1: Selection of scanning mode (please refer to the following table)

Setting of scan control input		IN/OUT state for start pulse				Scanning direction
UDC	LRC	STVD	STVU	STHR	STHL	
GND	V _{CC}	OUT	IN	OUT	IN	From up to down, and from left to right.
V _{CC}	GND	IN	OUT	IN	OUT	From down to up, and from right to left.
GND	GND	OUT	IN	IN	OUT	From up to down, and from right to left.
V _{CC}	V _{CC}	IN	OUT	OUT	IN	From down to up, and from left to right.

IN: Input; OUT: Output.

Note 2: Definition of scanning direction. Refer to figure as below:

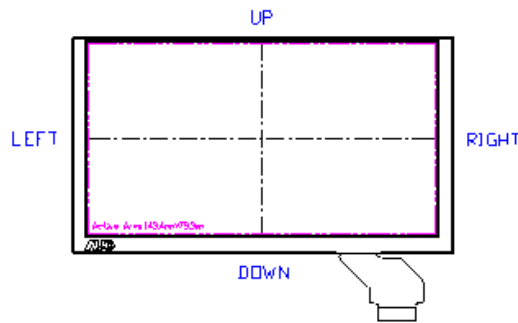

Note 3: MOD = H: Simultaneous sampling. MOD = L: Sequential sampling.

Please set CPH2 and CPH3 to GND when MOD = H.

Note 4: Electrical characteristics of V_{CC} and DV_{DD} are the same.

b. Backlight driving section (Refer to Fig. 1)

No.	Symbol	I/O	Description	Remark
1	HI	I	Power supply for backlight unit (High voltage)	
2	GND	-	Ground for backlight unit	

2. Absolute maximum ratings

Item	Symbol	Condition	Min.	Max.	Unit	Remark
Power voltage	V _{CC}	GND=0	-0.3	7	V	
	AV _{DD}	AGND=0	-0.3	7	V	
	V _{GH}	GND=0	-0.3	18	V	
	V _{GL}		-15	0.3	V	
	V _{GH} - V _{GL}		-	33	V	
Input signal voltage	V _i		-0.3	AV _{DD} +0.3	V	Note 1
	V _l		-0.3	V _{CC} +0.3	V	Note 2
	VCOM		-2.9	5.2	V	

Note 1: VR, VG, VB.

Note 2: STHL, STHR, OEH, LRC, CPH1~CPH3, STVD, STVU, OEV, CKV, UDC.

3. Environment condition

Item		Condition	Spec.	Remark
Operating temperature	Panel with lighting BLU	Ambient (panel surface)	-30 ~85°C	Note 1,2,3
Storage temperature	Panel with lighting BLU	Surface temperature	-40 ~95°C	Note 4
	Panel	Surface temperature	-40 ~95°C	

Note 1: Under the condition of the operating temperature, the panel would be function normal for the visual display only. For contrast, response time, and other factors related to display quality, determine temperature using the formula $T_a=25^\circ\text{C}$

Note 2: Panel surface temperature is defined as the maximum temperature of panel surface. In general, the lamp side temperature is higher than non-lamp side around 10°C

Note 3: The backlight has been turned on before running about condition.

Note 4: BLU is off

4. Electrical characteristics

a. Typical operating conditions (GND=AGND=0V, Note 3)

Item	Symbol	Min.	Typ.	Max.	Unit	Remark
Power supply	V_{CC}	3	5	5.5	V	
	AV_{DD}	4.5	5	5.5	V	
	V_{GH}	14.3	15	15.7	V	
	V_{GL}	-10.5	-10	-9.5	V	
Video signal amplitude (VR, VG, VB)	V_{iA}	0.4	-	$AV_{DD}-0.4$	V	Note 1
	V_{iAC}	-	3	-	V	AC component
	V_{iDC}	-	$AV_{DD}/2$	-	v	DC component
VCOM	V_{CAC}	3.5	5.6	6.5	Vp-p	AC component
	V_{CDC}	(1.4)	(1.7)	(2.0)	V	DC component
Input signal voltage	H Level	V_{IH}	$0.8V_{CC}$	-	V_{CC}	Note 2
	L Level	V_{IL}	0	-	$0.2V_{CC}$	

Note 1: Refer to Fig.4-(a).

Note 2: STHL, STHR, OEH, LRC, CPH1~CPH3, STVD, STVU, OEV, CKV, UDC

Note 3: Be sure to apply GND, V_{CC} and V_{GL} to the LCD first, and then apply V_{GH} .

b. Current consumption (GND=AGND=0V)

Parameter	Symbol	Condition	Min.	Typ.	Max.	Unit	Remark
Current for driver	I_{GH}	$V_{GH}=15V$	-	0.20	0.5	mA	
	I_{GL}	$V_{GL}=-10V$	-	0.80	1.5	mA	
	I_{CC}	$DV_{DD}=5V$	-	3.0	6.0	mA	Note 1
	I_{DD}	$AV_{DD}=5V$	-	17.0	30	mA	



Note 1: I_{CC} is current consumption of DV_{DD} plus V_{CC} .

c. Backlight driving conditions

Parameter	Symbol	Min.	Typ.	Max.	Unit	Remark
Lamp voltage	V_L	-	530	580	Vrms	Note 7
Lamp current	I_L	-	6	6.5	mArms	
Frequency	F_L	-	60	80	kHz	Note 4
Lamp starting voltage	V_S	-	820	1020	Vrms	Note 1,5
		-	1060	1330	Vrms	Note 2,5
		-	1270	1590	Vrms	Note 3,5
Lamp life time		(10000)	(15000)	-	Hr	Note 6

Note 1: $T_a = 25^{\circ}C$.

Note 2: $T_a = 0^{\circ}C$.

Note 3: $T_a = -30^{\circ}C$.

Note 4: The lamp frequency should be selected as different as possible from display horizontal synchronous signal to avoid interference.

Note 5: For starting the backlight unit, the output voltage of DC/AC's transformer should be larger than the maximum lamp starting voltage.

Note 6: The" Lamp life time" is defined as the module brightness decrease to 50% original brightness at $T_a=20\sim35^{\circ}C$ (With no wind), $I_L=6.5mA$ MAX (Continuously operation).

Note 7: The Lamp voltage shall be lighted at constant lamp current ($I_L:6.0mA$)and shall be measured after 20 minutes.

5. AC Timing

a. Timing conditions

Parameter	Symbol	Min.	Typ.	Max.	Unit.	Remark
Rising time	t_r	-	10	25	ns	Note 1
Falling time	t_f	-	10	25	ns	Note 1
High and low level pulse width	t_{CPH}	121	126	131	ns	CPH1~CPH3
CPH pulse duty	t_{CWH}	40	50	60	%	CPH1~CPH3
CPH pulse delay	t_{C12} t_{C23} t_{C31}	30	$t_{CPH}/3$	$t_{CPH}/2$	ns	CPH1~CPH3
STH setup time	t_{SUH}	20	-	-	ns	STHR, STHL
STH hold time	t_{HDH}	20	-	-	Ns	STHR, STHL
STH pulse width	t_{STH}	-	1	-	t_{CPH}	STHR, STHL
STH period	t_H	61.5	63.5	65.5	μs	STHR, STHL
OEH pulse width	t_{OEH}	-	1.22	-	μs	OEH
Sample and hold disable	t_{DIS1}	-	8.28	-	μs	
OEV pulse width	t_{OEV}	-	5.40	-	μs	OEV
CKV pulse width	t_{CKV}	-	4.18	-	μs	CKV
Clean enable time	t_{DIS2}	-	3.74	-	μs	
Horizontal display start	t_{SH}	-	0	-	$T_{CPH}/3$	
Horizontal display timing range	t_{DH}	-	1200	-	$T_{CPH}/3$	
STV setup time	t_{SUV}	400	-	-	ns	STVU, STVD
STV hold time	t_{HDV}	400	-	-	ns	STVU, STVD
STV pulse width	t_{STV}	-	-	1	t_H	STVU, STVD
Horizontal lines per field	t_V	256	262	268	t_H	Note 2
Vertical display start	t_{SV}		3	-	t_H	
Vertical display timing range	t_{DV}		234	-	t_H	
VCOM rising time	t_{rCOM}		-	5	μs	
VCOM falling time	t_{fCOM}		-	5	μs	
VCOM delay time	t_{DCOM}		-	3	μs	
RGB delay time	t_{DRGB}		-	1	μs	

Note 1: For all of the logic signals.

Note 2: Please don't use odd horizontal lines to drive LCD panel for both odd and even field simultaneously.

b. Timing diagram

Please refer to the attached drawing, from Fig.2 to Fig.6.

6. Power Sequence (Suggestion)
 Sequence for power on/off and Signal on/off

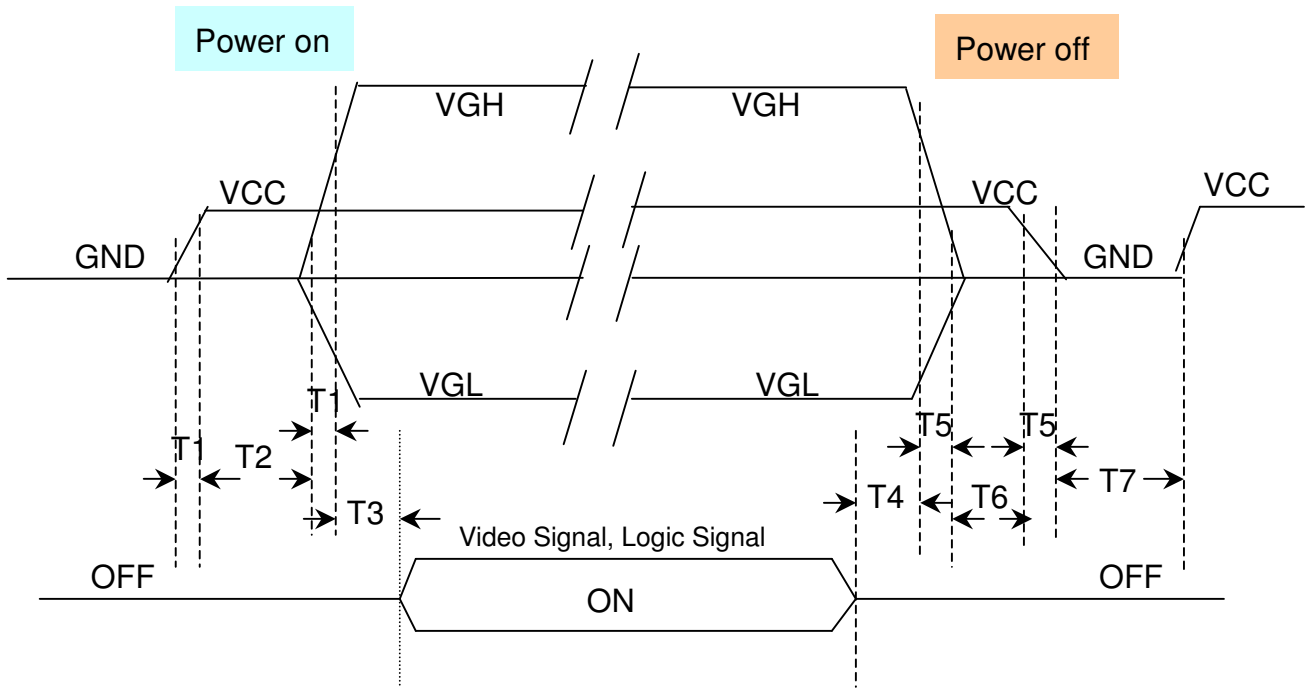

- T1 \cong 15ms (From 10%*VCC to 90%*VCC , when VCC is Low to High) ;
- T2 \cong 10ms (From 90%*VCC to 10%*VGH , when VCC is Low to High) ;
- T3 \cong 10ms (From 90%*VGH to Video signal , when VGH is Low to High) ;
- T4 \cong 10ms (From Video signal to 90%*VGH , when VGH is High to Low) ;
- T5 \cong 20ms (From 90%*VCC to 10%*VCC , when VCC is High to Low) ;
- T6 \cong 10ms (From 10%*VGH to 90%*VCC , when VCC is Low to High) ;
- T7 \cong 0.4s (From 10%*VCC is H→L to 10%*VCC is L→H)

C. Optical specification (Note 1)

Item		Symb	Condition	Min.	Typ.	Max.	Unit	Remark
Response time	Rise	Tr	$\theta = 0^\circ$	-	15	50	ms	Note 2,4
	Fall	Tf		-	20	60	ms	
Contrast ratio		CR	At optimized Viewing angle	100	300	-		Note 3,4
Viewing angle	Top	$CR \geq 10$		20	40	-	deg.	Note 4,6
	Bottom			40	55	-		
	Left			45	60	-		
	Right			45	60	-		
	Top	$CR \geq 5$		30	50	-	deg.	Note 4,5
	Bottom			60	70	-		
	Left			60	70	-		
	Right			60	70	-		
Brightness		Y _L	I _L =6mA, 25°C	400	500	-	nit	Note 6
			I _L =9.5mA, -10°C, 1min	(140)	(190)		nit	
			I _L =9.5mA, -20°C, 1min	(70)	(120)	-	nit	
White chromaticity		X	$\theta = 0^\circ$	0.26	0.31	0.36		Note 6
		Y	$\theta = 0^\circ$	0.28	0.33	0.38		

Note 1 : Ambient temperature =25°C. And lamp current I_L = 6 mArms. To be measured in the dark room and to be measured on the center area of panel with a viewing cone of 1°by Topcon luminance meter BM-5, after 20 minutes operation.

Note 2. Definition of response time:

The output signals of photo detector are measured when the input signals are changed from “black” to “white”(falling time) and from “white” to “black”(rising time), respectively. The response time is defined as the time interval between the 10% and 90% of amplitudes. Refer to figure as below.

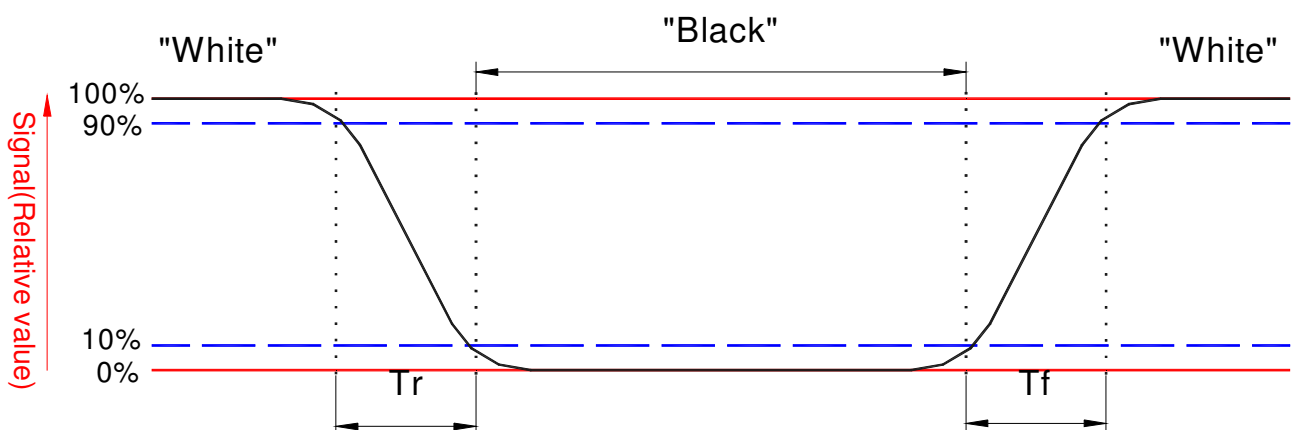

Note 3. Definition of contrast ratio:

Contrast ratio is calculated with the following formula.

$$\text{Contrast ratio (CR)} = \frac{\text{Photo detector output when LCD is at "White" state}}{\text{Photo detector output when LCD is at "Black" state}}$$

Note 4. White $V_i = V_{i50} + 1.5V$

Black $V_i = V_{i50} \pm 2.0V$

“±” means that the analog input signal swings in phase with V_{COM} signal.

“ \mp ” means that the analog input signal swings out of phase with V_{COM} signal.

V_{i50} : The analog input voltage when transmission is 50%

The 100% transmission is defined as the transmission of LCD panel when all the input terminals of module are electrically opened.

Note 5. Definition of viewing angle, refer to figure as below.

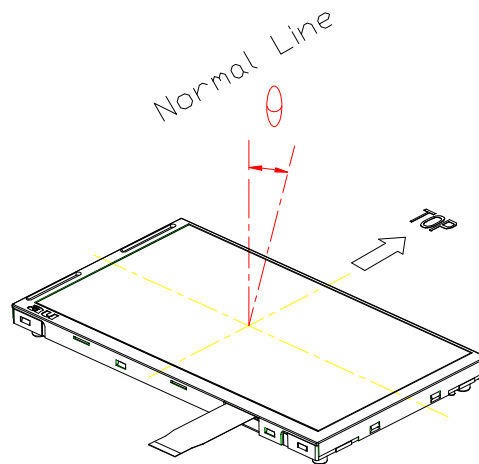

Note 6. Measured at the center area of the panel when all the input terminals of LCD panel are electrically opened.

Note 7. It is combine with application circuit which AU Optronics recommendation.

D. Reliability test items(Note 2):

No.	Test items	Conditions	Remark
1	High temperature storage	Ta= 95°C 240Hrs	
2	Low temperature storage	Ta= -40°C 240Hrs	
3	High temperature operation	Ta= 85°C 240Hrs	
4	Low temperature operation	Ta= -30°C 240Hrs	
5	High temperature and high humidity	Ta= 60°C, 90% RH 240Hrs	Operation
6	Heat shock	-30°C~85°C/200 cycles 1Hrs/cycle	Non-operatio
7	Electrostatic discharge	±200V,200pF(0Ω), once for each terminal	Non-operatio
8	Vibration	Frequency range : 8~33.3Hz Stoke : 1.3mm Sweep : 2.9G,33.3~400Hz 2 hours for each direction of X, Z 4 hours for direction of Y	JIS D1601, A-10 condition A Note3
9	Mechanical shock	100G, 6ms, ±X,±Y,±Z 3 times for each direction	JIS C7021, A-7 condition C
10	Vibration (with carton)	Random vibration: 0.015G ² /Hz from 5~200Hz -6dB/octave from 200~500Hz	IEC 68-34
11	Drop (with carton)	Height: 60cm 1 corner, 3 edges, 6 surfaces	JIS Z0202

Note 1: Ta: Ambient temperature.

Note 2: In the standard conditions, there is not display function NG issue occurred. All the cosmetic specification is judged before the reliability stress.

Note 3: Cycle time for vibration test is 15 minutes.

E. Packing form

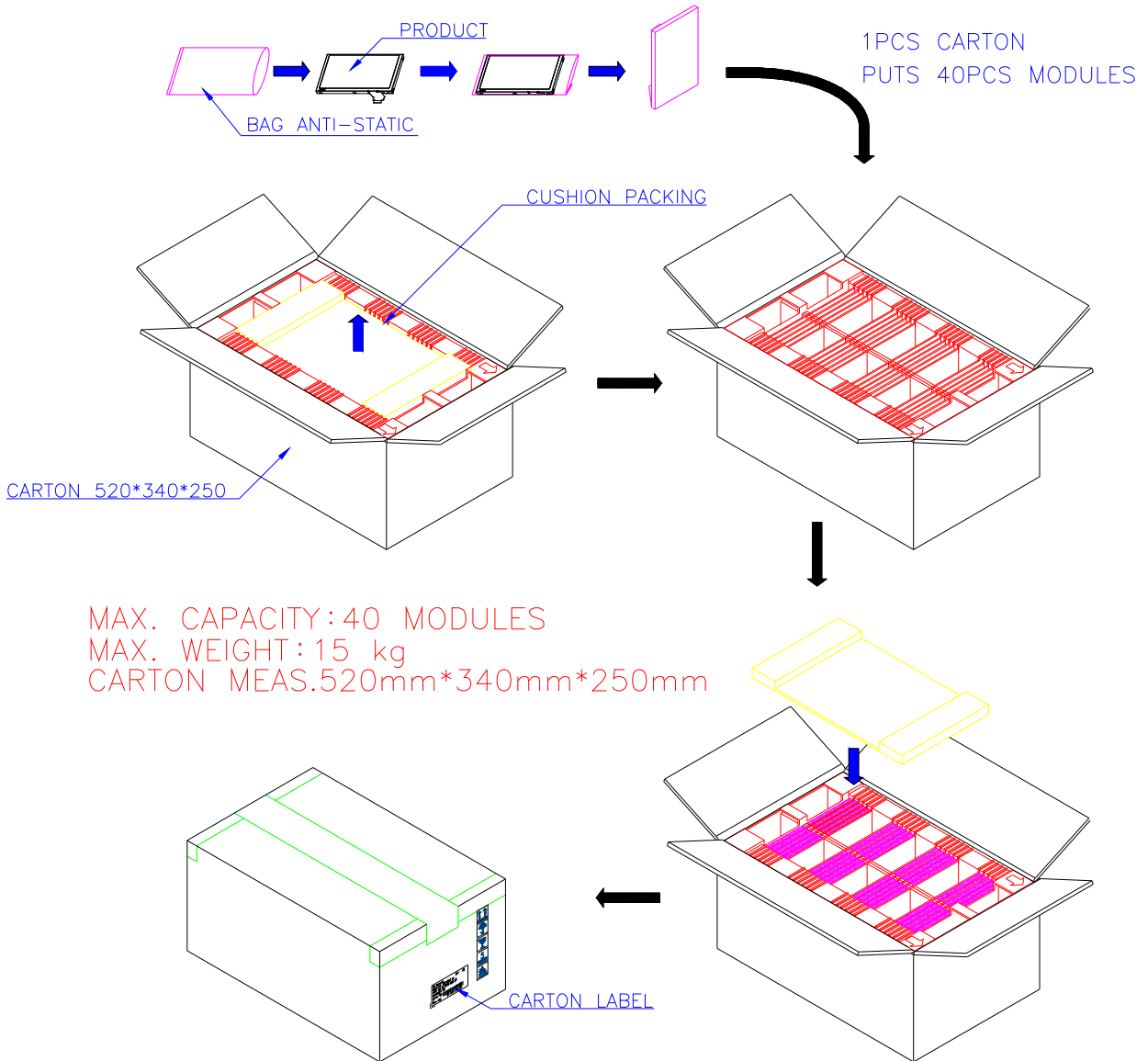

NOTE:
 1. General tolerance is $\pm 0.3\text{mm}$.
 2. The bending radius of FPC should be larger than 0.6mm .

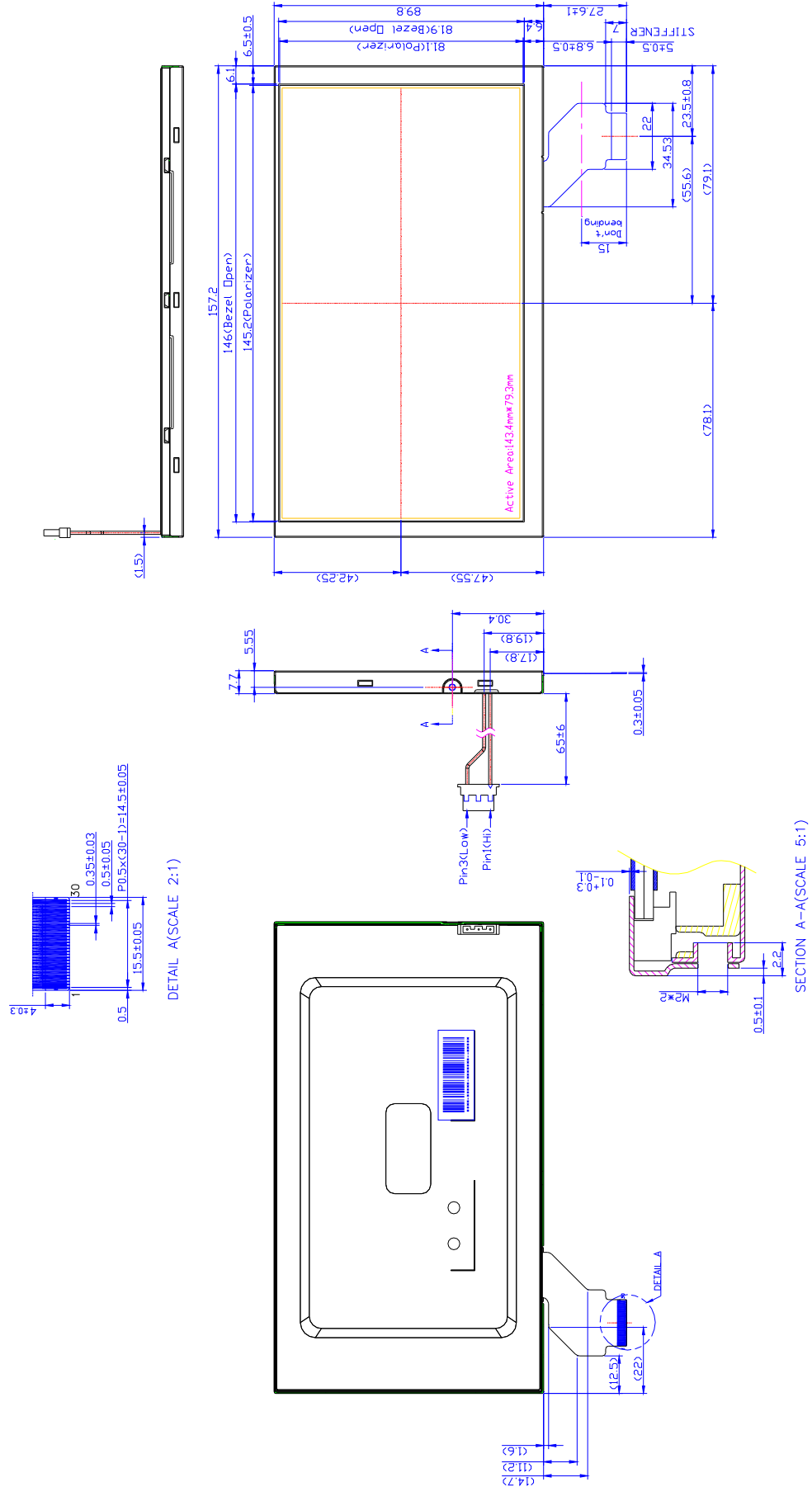

Fig.1-(a) Outline dimension of TFT-LCD module

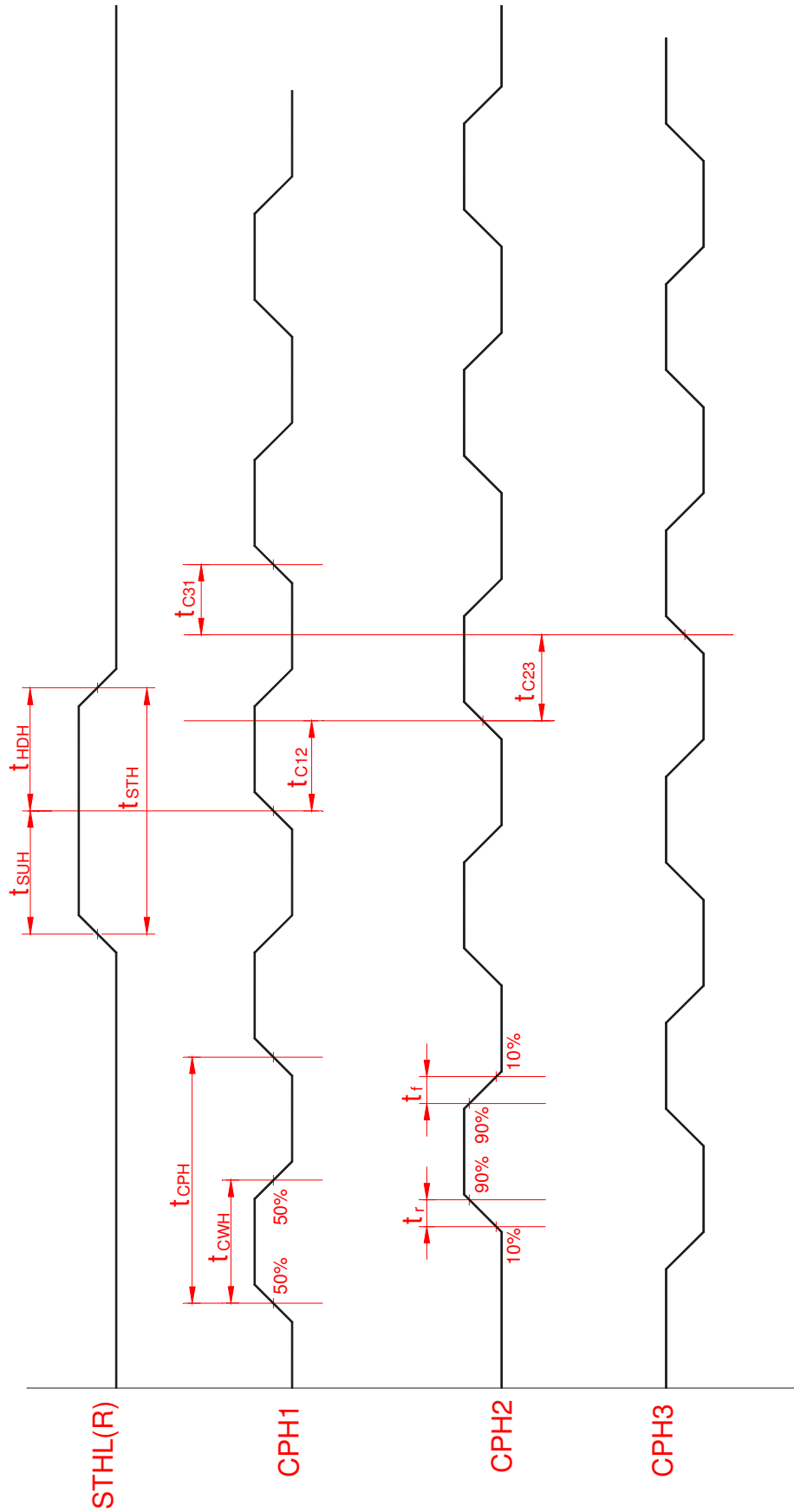

Fig.2 Sampling clock timing

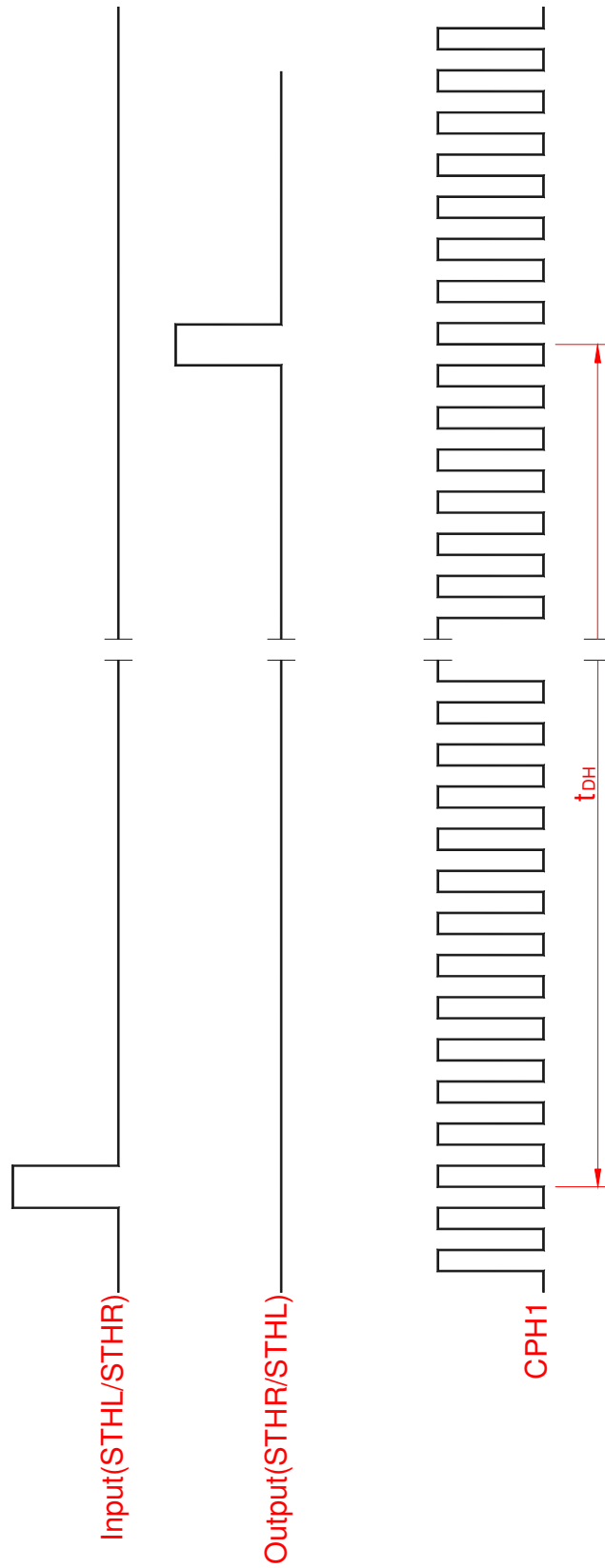

Fig.3 Horizontal display timing range

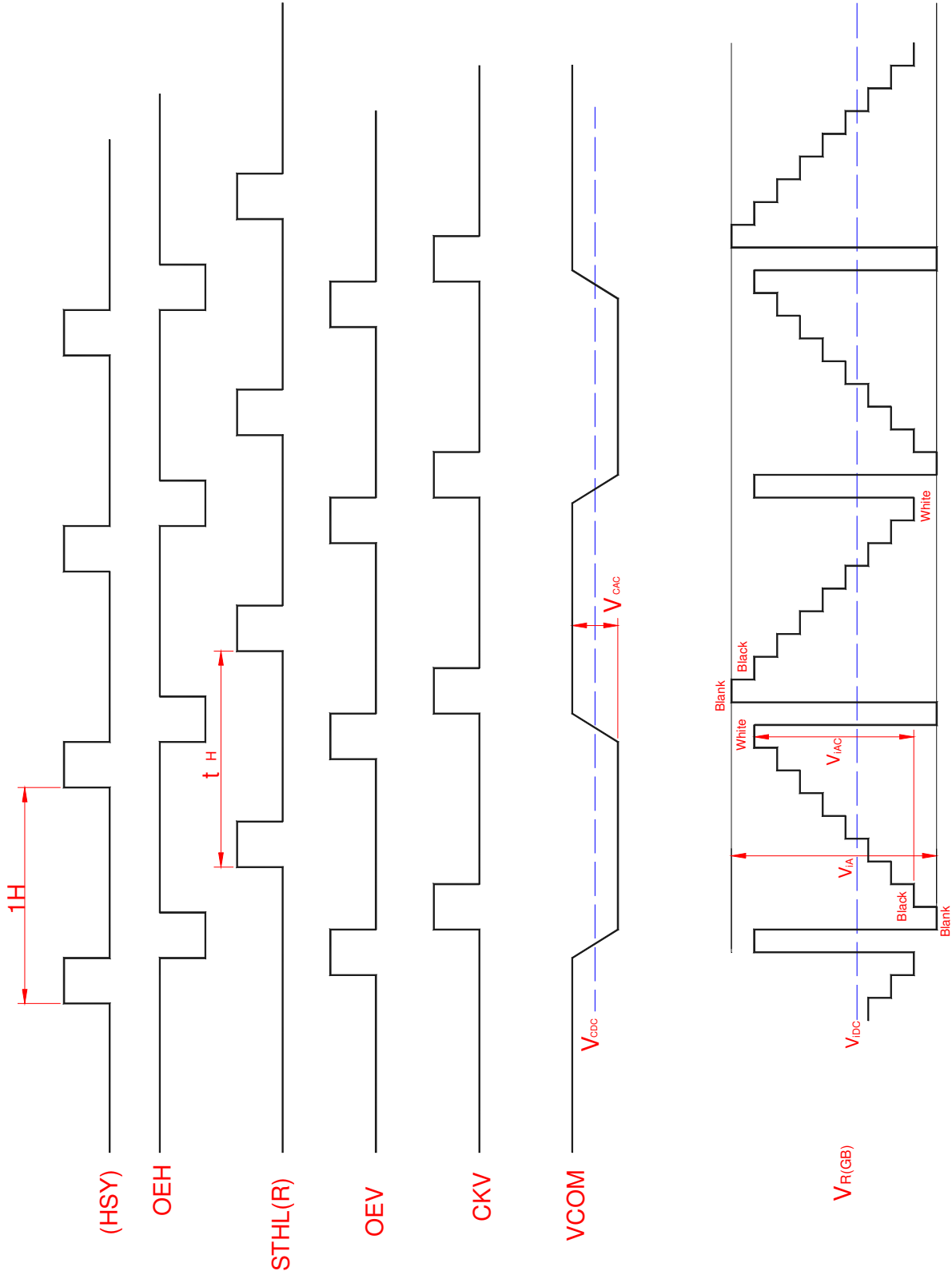
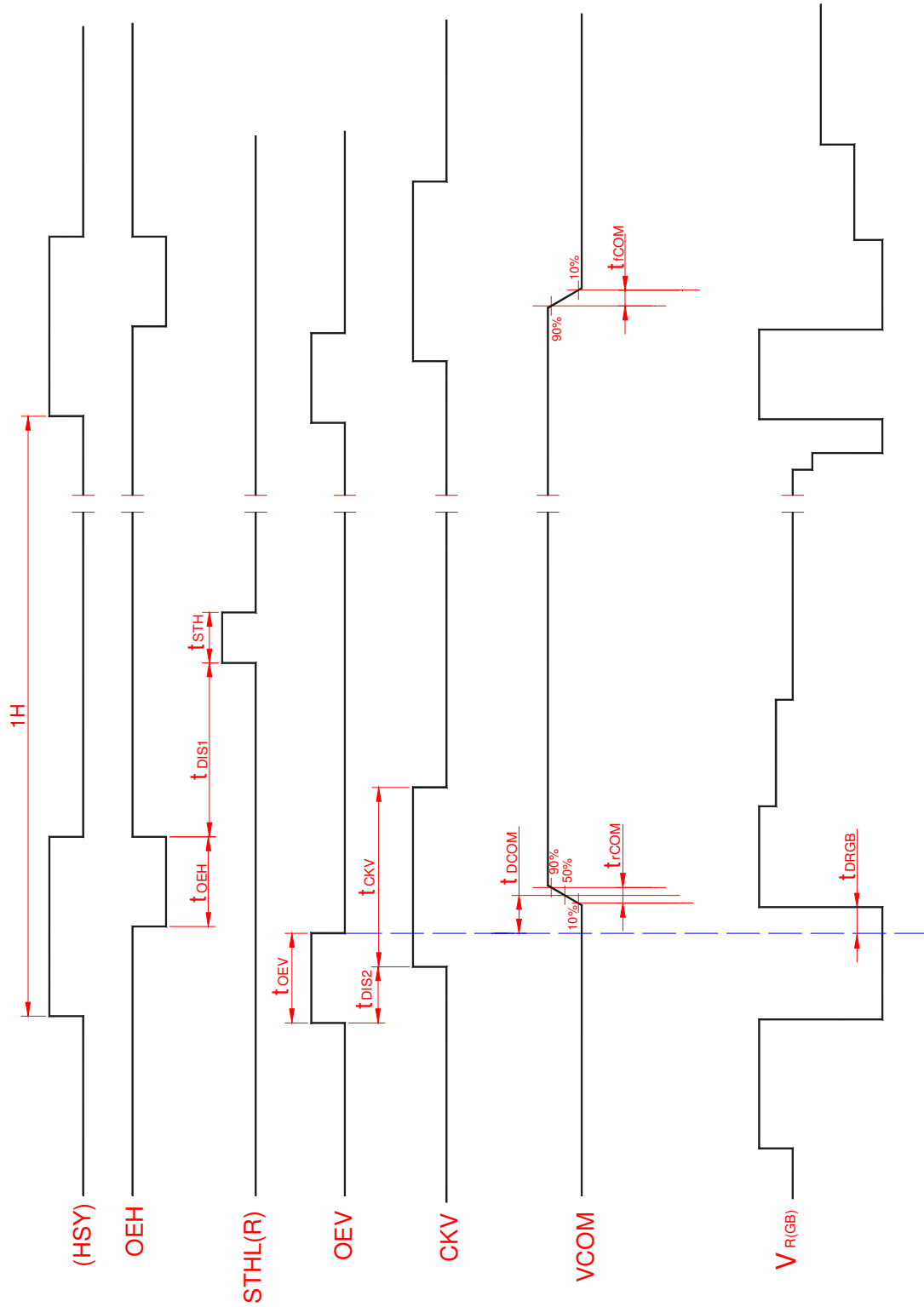

Fig.4-(a) Horizontal timing



Note: The falling edge of OEV should be synchronized with the falling edge of OEH

Fig.4-(b) Detail horizontal timing

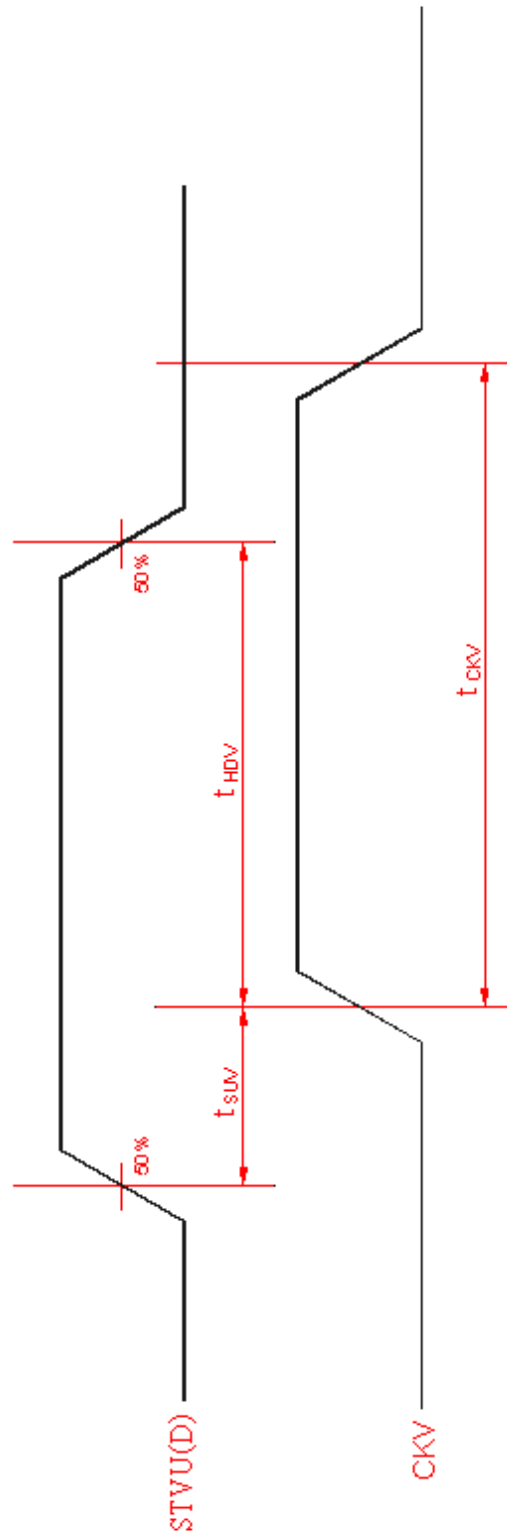

Fig.5 Vertical shift clock timing

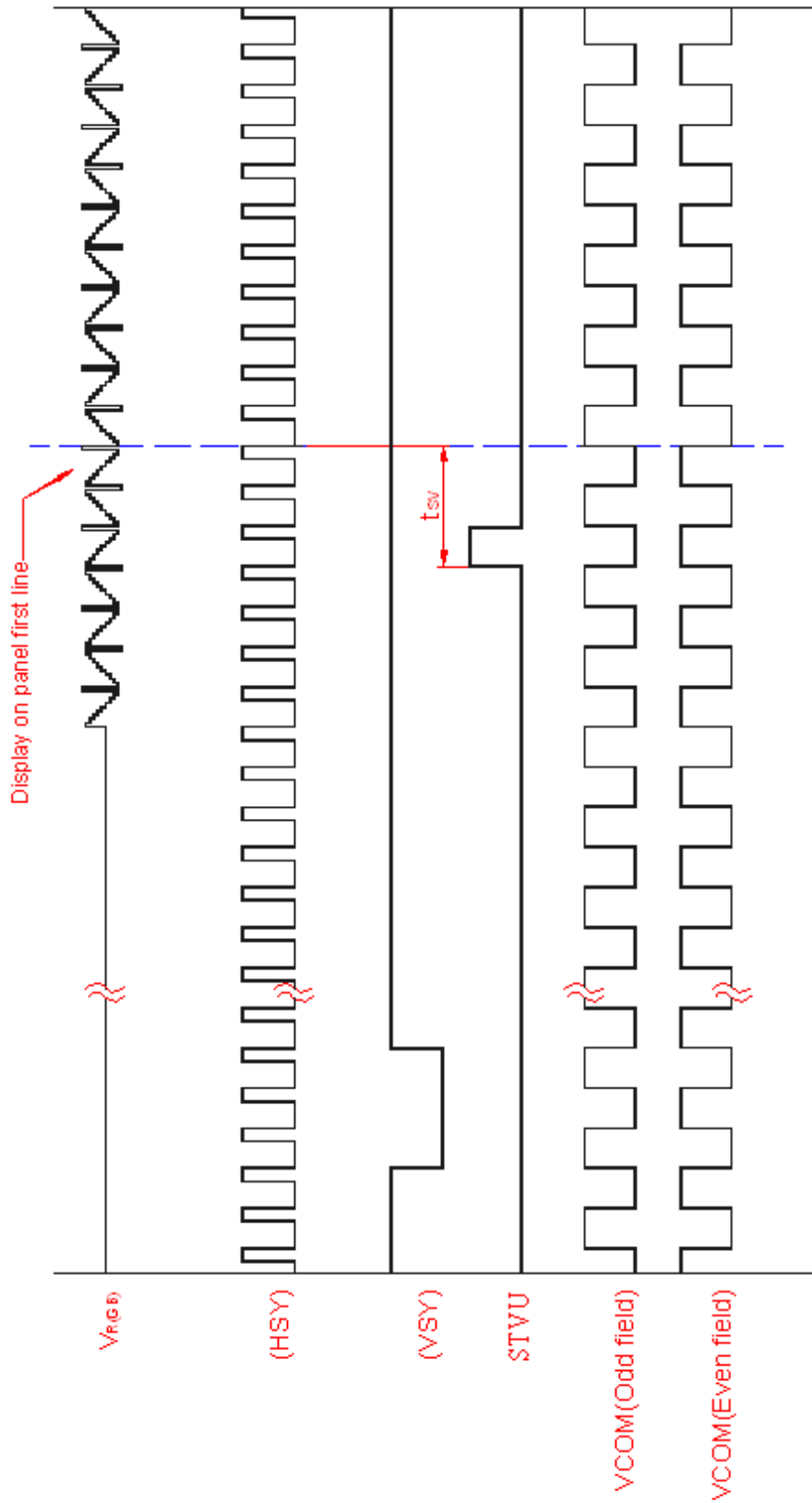

Fig.6-(a) Vertical timing (From up to down)

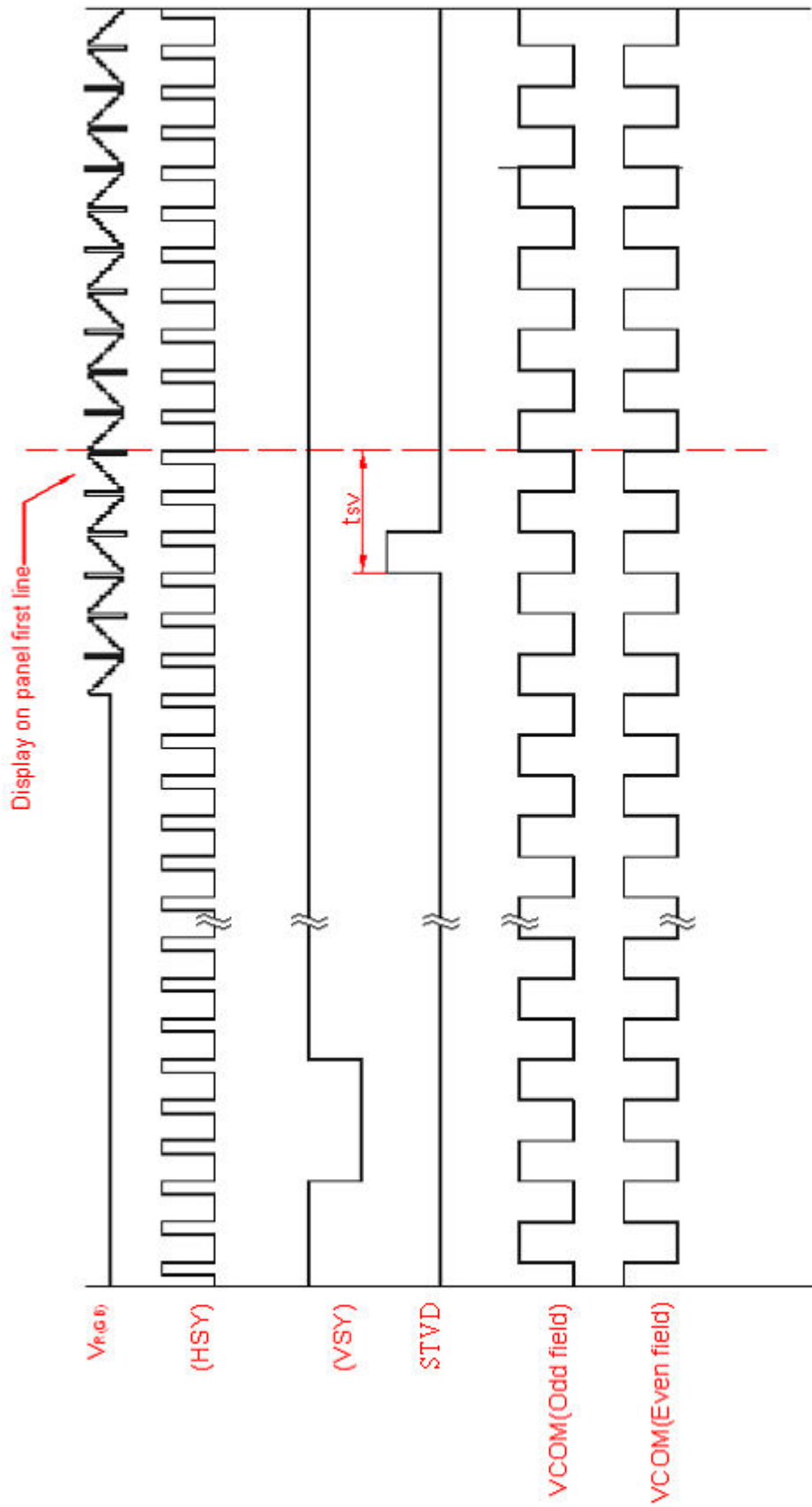

Fig.6-(b) Horizontal timing (From down to up)